

Rough Rider Sipariş Formu



Siz: Adı, Soyadı: _____

Tarih:

Ünvanı: _____

Erkek

Yaş:

Boy:

Kadın

Tanı:

1. Oturak Genişliği

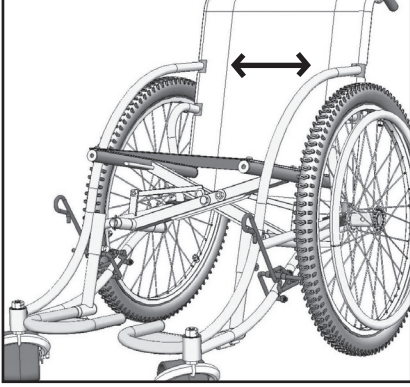

- 32 cm
 36 cm
 40 cm
 44 cm
 48 cm

3. Sırtlık Seviyesi

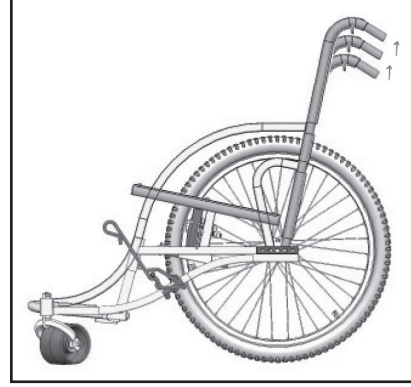

- 48,5 cm
 43,5 cm (standart)
 38,0 cm

2. Arka Tekerlek Konumu

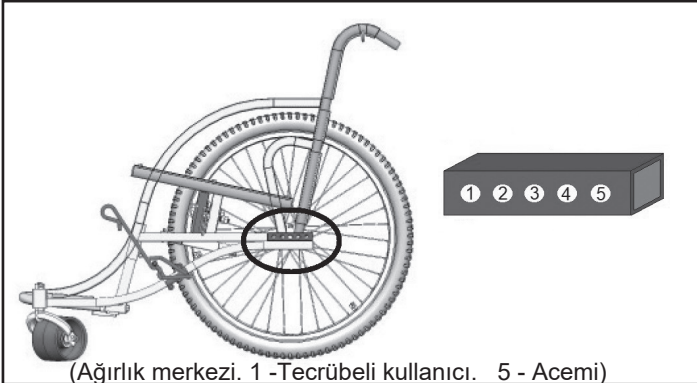

(Ağırlık merkezi. 1 - Tecrübeli kullanıcı. 5 - Acemi)

- 1 2 3 4 5



4. Ayaklık Seviyesi

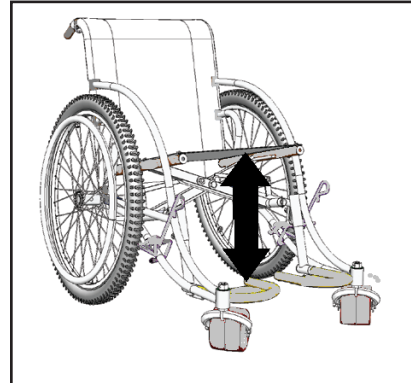

Minimum 30 cm

cm

Maksimum 43 cm

(Minder kalınlığını ilave edin.)

Dahilinde:

- * 5 cm sünger konfor minderi
- * Kullanma Kılavuzu
- * El pompası
- * Yama seti
- * Yantıl anahtarı
- * Standart renk: mat siyah

Sigortalının adı, soyadı:

T.C. Kimlik Nos:

Fatura adres ve telefonunu nosu:

Teslimat adres ve telefon nosu:

KİFAS ORTOPEDİK ÜRÜNLER SAN. VE TİC. LTD. ŞTİ

İvedik OSB - Has Emek Koop

1468 Cad. No. 47 / 06378 Yenimahalle - Ankara

Tel: +90 312 395 6652 Fax: +90 312 395 66 84

Gsm: +90 530 400 34 50 satis@kifas.com.tr

GARANTİ BBVA IBAN NO: TR 79 0006 2001 4950 0006 2961 45